



**(An Autonomous Institution - AFFILIATED TO ANNA UNIVERSITY, CHENNAI)**

**S.P.G.Chidambara Nadar - C.Nagammal Campus**

**S.P.G.C. Nagar, K.Vellakulam – 625 701 (Near VIRUDHUNAGAR).**

**DEPARTMENT OF MECHANICAL ENGINEERING**

**Value Added Course**

**on**

**NX CAD – Beginners**

Academic Year : 2022-2023 (ODD Semester)

(Batch I) : 23.08.2022 to 25.08.2022

Date

(Batch II) : 26.08.2022 to 28.08.2022

Duration : 24 Hours

Organized by : Centre for Excellence in Manufacturing,  
NIT – Trichy

**VAC Coordinator**

**HoD/Mech**

**Dean (Academic Courses)**



(An Autonomous Institution - AFFILIATED TO ANNA UNIVERSITY, CHENNAI)

S.P.G.Chidambara Nadar - C.Nagammal Campus  
S.P.G.C. Nagar, K.Vellakulam - 625 701 (Near VIRUDHUNAGAR).

## DEPARTMENT OF MECHANICAL ENGINEERING

Content		Details
Academic Year		2022-2023 (ODD Semester)
Date	(Batch I)	23.08.2022 to 25.08.2022
	(Batch II)	26.08.2022 to 28.08.2022
Name of the Value-added course		NX CAD - Beginner
Duration		24 Hours
No of Credit		1 Credit
Category		Hands-on and lab
Organized by		Centre for Excellence in Manufacturing, NIT - Trichy
External Coordinator		Dr. V. Anandkrishnan, Coordinator and Associate Centre Head, CoE, NIT - Trichy
Three Member Committee Members		1. Dr. S.S. Saravana kumar, ASP & HoD/Mech 2. Dr. S. Senthil, Prof. & Principal 3. Er. N.R. Madhan, AP/Mech
Internal Coordinators		Er. N.R. Madhan, AP/Mech Er. R. Sakthivel Murugan, AP/Mech

*N.R. Madhan*  
*R. Sakthivel Murugan*  
VAC Coordinator

*R.M.*  
HoD/Mech

*N.S. - Bar*  
*26/11/22*  
Dean (Academic Courses)

# KAMARAJ

## COLLEGE OF ENGINEERING & TECHNOLOGY



(An Autonomous Institution - Affiliated to Anna University, Chennai)

S.P.G. Chidambara Nadar - C.Nagammal Campus

S.P.G.C. Nagar, K. Vellakulam - 625 701, (Near Virudhunagar), Madurai District.

Submitted to the SECRETARY for approval through the PRINCIPAL

Book No.

MECH

Date 17/08/2022

SL.No.

22

Value Added Course | III year | Nx - CAD

As oral discussion on 15-08-2022, VAC on Nx-CAD for III year students is going to conduct by COE - Manufacturing, NIT.

COURSE NAME : Nx - CAD

COURSE FEES. : Rs 2400/student [inclusive of tax]

COURSE DURATION : ~~23-08-2022 to 28-08-2022~~ [2 Batches] [Each 3 Days]

Note: 1. The institute required full payment [NO TDS has to be deducted from our end]  
2. They required full payment before the course start.

Enclose: company mail - confirmation with acceptance.

S.P.G.  
17/08/2022  
Signature of Faculty

17/08/22  
HOD

S.P.G.  
18/08/22  
PRINCIPAL

### OFFICE USE

- 1) Account Head
- 2) Budget allotted
- 3) Amount committed / Spent so far
- 4) Balance available

Value Added Course

OM

S.P.G.  
Treasurer

S.P.G.  
Secretary

---

**From:** Sakthivel Murugan.R  
**Sent:** 15 August 2022 12:37  
**To:** 20UME  
**Cc:** HODMECH; Madhan.N.R  
**Subject:** Value Added Course | R2020 | Course Details

Dear Students,

Value Added Course is planned for all III Year Students. It is a mandatory course and an opportunity to avail over and above credit in R2020.

**VAC Details:**

Course Theme: NX beginner's course in design

Organized by : Center of Excellence in Manufacturing, NIT Trichy

Mode: Offline

Duration : 3 Days (2 Batches)

Batch Details: Same as Academics Lab Batches

Batch 1 Date : [23.08.2022](#) to [25.08.2022](#)

Batch 2 Date : [26.08.2022](#) to [28.08.2022](#)

Time : 09.00 A.M to 04.00 P.M

Accommodation in Trichy:

Should be arranged by student itself due to constraints in NITT Hostel.

Certificate Eligibility : 100% Attendance & Eligible mark in the assessment.

Regarding this, a meeting is scheduled to discuss about the course details, accommodation, lunch etc.

Meeting Details:

Meeting Date: [16.08.2022](#)

Day : Tuesday

Time : 10.00 AM

Venue : E15

Students are requested to be available in the venue on proper time.

Meeting Agenda:

- 1.HOD/Mech will address the meeting
- 2.VAC incharge will deliver the Course Details and plan
- 3.Chairperson will deliver the Vote of thanks

Your Kind cooperation is solicited.

Regards,

Sakthivel Murugan R,  
Chairperson.

---

**From:** NITT COE

**Sent:** 22 August 2022 11:05

**To:** Madhan.N.R

**Cc:** Sakthivel Murugan.R; HODMECH; Dr.SENTHIL.S; Dr V ANANDAKRISHNAN

**Subject:** Re: Confirmation Mail | RE: Value Added Course | Request | Slot

Dear Sir,

Please find the requested information for your reference.

**INTERNSHIP FOR KAMARAJ ENGINEERING COLLEGE STUDENTS: 23.08.2022  
to 28.08.2022**

Timing: 9.30 a.m. To 05.30 p.m.

**Batch 1:** (24 Students)

S. No.	Date and Day	Forenoon	Afternoon
1.	23.08.2022 Tuesday	NX CAD Introduction and Sketching	Sketching Practice and NX CAD Modelling
2.	24.08.2022 Wednesday	Modelling Practice	NX CAD Assembly
3.	25.08.2022 Thursday	NX CAD Assembly Practice	NX CAD Drafting

**Batch 2:** (24 Students)

S. No.	Date and Day	Forenoon	Afternoon
1.	26.08.2022 Friday	NX CAD Introduction and Sketching	Sketching Practice and NX CAD Modelling
2.	27.08.2022 Saturday	Modelling Practice	NX CAD Assembly
3.	28.08.2022 Sunday	NX CAD Assembly Practice	NX CAD Drafting

## Syllabus for NX CAD for Beginners

**Introduction:** Introduction to NX - New file overview - Layers - Show and Hide - Working with the Teamcenter Navigator - Working with folders in NX - Create a new folder for your part files

**Sketching:** Sketch overview - Sketch curves - Sketch curve functions - Types of constraints - Sketch dimensions - Convert To/From Reference - Activities: Create constraints.

**Modelling:** Types of swept features - Internal and external sketches – Extrude - Combining bodies using Boolean commands - Body type - Revolve - Sweep along Guide - Create a simple sweep along guide feature - Activities: Swept features - Summary: Swept features. Hole features: Hole overview Hole overview – Hole dialog box - Hole position and direction options - Hole form and dimension options - Create a General Hole feature - Activities: Hole features - Summary: Hole features. Edge operations: Edge Blend overview - Activities: Edge operations - blends – Chamfer overview - Create a Chamfer - Chamfer options - Activities: Edge operations – chamfers.

**Assembly:** Assembly - Subassembly - Component objects - Component Part Files - Assembly Load Options group - Load states - Scope group - Reference Sets - Saved Load Options - Activities: Assemblies - assembly load options and the Assembly Navigator – Select components - Assembly Navigator display commands - Activities: Assemblies – more navigator options - Part revisions and saving assemblies /Save / Save Work Part Only. Adding and constraining components: General assembly concepts - Bottom-up assembly modeling - Activities: Adding components - create assembly - Move Component /Move Component options - Assembly Constraints - Show Degrees of Freedom - Activities: Adding and constraining components - constrain.

**Drafting** - Create drawings -Change drawing display to - Drafting View Style and View Preferences - The View Creation Wizard-Base View/Projection views - Edit the style of an existing view - Drag views on a drawing - views on a drawing - Activities: Drafting - add views - Dimensions - Activities: Drafting – dimensions - Activities: Drafting - Notes and labels

Thanks and Regards,  
Vignesh S.  
Junior Engineer  
Center of Excellence in Manufacturing  
National Institute of Technology  
Tiruchirappalli- 620 015  
Tamilnadu  
Ph: 9486001131

Approved  
RM

med  
R. d. d. d.

**DEPARTMENT OF MECHCHANICAL ENGINEERING**

Value Added Course on HVAC

Conducted : EXCEL MEP, Bangalore

Year / Sem : III / IV

Course duration : 28.03.2022 to 30.03.2022

Batch : 2019 - 23

Duration of the Course : 24 Hrs

**Approval of Programme Assessment Committee**

Board of Study Meeting: IV

Mode: online (MS-Teams)

Date & Timing: 19.03.2022 & 3.00PM

Page No: 17 of 18

**Dr. S. Thanga Kasi Rajan presented the list of value-added courses. The following discussions were made.**

S.No.	Course Title	Total hours	Credits
1.	Programming on Computer Numerical Control		2
2.	Advanced Pro-E		2
3.	Machine Learning		2
4.	Block chain		2
5	Heating, Ventilation and Air Conditioning		2

The members of BoS recommend and proceed the same.

*N.R. Madhavan*

VAC Coordinators

*S.S. Suresh*

HoD/MECH



**DEPARTMENT OF MECHANICAL ENGINEERING**

**Three-member committee meeting for value added course selection**

Agenda	Value Added Course Selection Meeting
Date	: 01/08/2022
Time	: 03.00 PM
Venue	: HoD/Mech Cabin, Academic Block E, Third Floor
Members Present	<p><b>Three Member Committee Members</b></p> <ol style="list-style-type: none"> <li>1. Dr. S.S. Saravana kumar, ASP &amp; HoD/Mech</li> <li>2. Dr. S. Senthil, Prof. &amp; Principal</li> <li>3. Er. N.R. Madhan, AP/Mech</li> </ol> <p><b>UG Coordinator</b></p> <ol style="list-style-type: none"> <li>4. Dr. S. Thanga Kasi Rajan, AP/Mech</li> </ol> <p><b>Chairperson cum CAD Lab Expert</b></p> <ol style="list-style-type: none"> <li>5. Er. R. Sakthivel Murugan, AP/Mech</li> </ol> <p><b>Domain Experts</b></p> <ol style="list-style-type: none"> <li>6. Dr. B. Prabhu, AP/Mech</li> <li>7. Dr. B. Balavairavan, AP/Mech</li> <li>8. Dr. S. Thanga Kasi Rajan, AP/Mech</li> </ol> <p><b>Class representative (2020 – 2024 Batch)</b></p> <ol style="list-style-type: none"> <li>9. Mr. K. Jaideepkumar (20ume016), II<sup>nd</sup> Year/ Student</li> <li>10. Mr. V.V. Premkumar (20ume031), II<sup>nd</sup> Year/ Student</li> <li>11. Mr. M. Harisuriya (20ume030), II<sup>nd</sup> Year/ Student</li> </ol>
Minutes of the Meeting	<p>1. It is optional to complete a Value-Added Course for Regulation 2020. In this regard a three-member committee has been formed and a meeting is organized to select the course for registration.</p> <ul style="list-style-type: none"> <li>• Meeting started by 3.00 PM. Dr. S.S. Saravana Kumar, Associate Professor &amp; Head of the Department, welcome the gathering.</li> <li>• Er. R. Sakthivel Murugan, Assistant Professor &amp; Chairperson of 2020-2024 batch has proposed various courses offered by             <ul style="list-style-type: none"> <li>○ Siemens Centre of Excellence in Manufacturing, National Institute of Technology, Tiruchirappalli and</li> <li>○ CIPET Madurai is offering NX-CAD</li> </ul> </li> <li>• Subject expects are suggested to offer Basic Robotic Simulation.</li> <li>• Dr.S.Thanga Kasi Rajan, Assistant Professor has advised to maintain SOP for value added course.</li> <li>• Based on the suggestion given by the Subject Expects &amp; 2020-2024 Batch Chairperson, 3 <sup>members</sup> committee members <sup>agreed to take</sup> for Value added course <sup>members</sup> NX - CAD course offered by</li> </ul>

COE in Manufacturing, NIT - Trichy, agree to take this for  
V semester for 2020-2024 Batch students

**Justification for the Course selection:**

The justification for the course selection were as follows

- i. This Course will be useful for her project work
- ii. It is a 24-hour course (1 Credit)
- iii. This Course is useful to beat Industrial Needs

20. 

**Three Member Committee Members**

Dr. S.S. Saravana kumar, ASP & HoD Mech  
Dr. S. Senthil, Prof & Principal  
Dr. N.R. Madhan, AP/Mech

1. 

2. 

3. 

**Domain Experts**

Dr. B. Prabhu, AP/Mech  
Dr. B. Balavarravan, AP/Mech  
Dr. S. Thanga Kasi Rajan, AP/Mech



**UG Coordinator**

Dr. S. Thanga Kasi Rajan, AP/Mech



**Chairperson**

Dr. R. Sakthivel Murugan, AP/Mech



**HoD/Mech**

  
26/11/2020  
**Dean Academics**



**Principal**



**NATIONAL INSTITUTE OF TECHNOLOGY  
TIRUCHIRAPPALLI – 620015  
CENTRE OF EXCELLENCE IN MANUFACTURING**

Certificate No. – NITT/CoEM/2022-23/INT07/01

# Certificate

This is to certify that **SAKTHIVEL.K** from **Kamaraj College of Engineering and Technology**, Madurai district, Tamilnadu has participated and successfully completed the course on **"NX CAD - Beginner"** conducted by the Centre of Excellence in Manufacturing, National Institute of Technology, Tiruchirappalli from 23<sup>rd</sup> August 2022 to 25<sup>th</sup> August 2022.

Dr.-Ing. M. Duraiselvam  
Coordinator/Dean P&D  
NIT, Trichy

Dr. V. Anandakrishnan  
Coordinator/Associate Centre Head  
CoE NIT, Trichy

Dr. D. Sriram Kumar  
Centre Head  
CoE NIT, Trichy



Certificate No. – NITT/CoEM/2022-23/INT07/02

**NATIONAL INSTITUTE OF TECHNOLOGY  
TIRUCHIRAPPALLI – 620015  
CENTRE OF EXCELLENCE IN MANUFACTURING**

# Certificate

This is to certify that **RAHUL.K** from **Kamaraj College of Engineering and Technology**, Madurai district, Tamilnadu has participated and successfully completed the course on "**NX CAD - Beginner**" conducted by the Centre of Excellence in Manufacturing, National Institute of Technology, Tiruchirappalli from 23<sup>rd</sup> August 2022 to 25<sup>th</sup> August 2022.

Dr.-Ing. M. Duraiselvam  
Coordinator/Dean P&D  
NIT, Trichy

Dr. V. Anandakrishnan  
Coordinator/Associate Centre Head  
CoE NIT, Trichy

Dr. D. Sriram Kumar  
Centre Head  
CoE NIT, Trichy



**NATIONAL INSTITUTE OF TECHNOLOGY  
TIRUCHIRAPPALLI – 620015  
CENTRE OF EXCELLENCE IN MANUFACTURING**

Certificate No. – NITT/CoEM/2022-23/INT07/03

# Certificate

This is to certify that **LOGESH.A** from **Kamaraj College of Engineering and Technology**, Madurai district, Tamilnadu has participated and successfully completed the course on **"NX CAD - Beginner"** conducted by the Centre of Excellence in Manufacturing, National Institute of Technology, Tiruchirappalli from 23<sup>rd</sup> August 2022 to 25<sup>th</sup> August 2022.

Dr.-Ing. M. Duraiselvam  
Coordinator/Dean P&D  
NIT, Trichy

Dr. V. Anandkrishnan  
Coordinator/Associate Centre Head  
CoE NIT, Trichy

Dr. D. Sriram Kumar  
Centre Head  
CoE NIT, Trichy



**NATIONAL INSTITUTE OF TECHNOLOGY  
TIRUCHIRAPPALLI – 620015  
CENTRE OF EXCELLENCE IN MANUFACTURING**

Certificate No. – NITT/CoEM/2022-23/INT07/04

# Certificate

This is to certify that **RAJA SRINIVAS.M** from **Kamaraj College of Engineering and Technology**, Madurai district, Tamilnadu has participated and successfully completed the course on **"NX CAD - Beginner"** conducted by the Centre of Excellence in Manufacturing, National Institute of Technology, Tiruchirappalli from 23<sup>rd</sup> August 2022 to 25<sup>th</sup> August 2022.

Dr.-Ing. M. Duraiselvam  
Coordinator/Dean P&D  
NIT, Trichy

Dr. V. Anandkrishnan  
Coordinator/Associate Centre Head  
CoE NIT, Trichy

Dr. D. Sriram Kumar  
Centre Head  
CoE NIT, Trichy



**NATIONAL INSTITUTE OF TECHNOLOGY  
TIRUCHIRAPPALLI – 620015  
CENTRE OF EXCELLENCE IN MANUFACTURING**

Certificate No. – NITT/CoEM/2022-23/INT07/05

# Certificate

This is to certify that **SANTHOSH.V** from **Kamaraj College of Engineering and Technology**, Madurai district, Tamilnadu has participated and successfully completed the course on **"NX CAD - Beginner"** conducted by the Centre of Excellence in Manufacturing, National Institute of Technology, Tiruchirappalli from 23<sup>rd</sup> August 2022 to 25<sup>th</sup> August 2022.

Dr.-Ing. M. Duraiselvam  
Coordinator/Dean P&D  
NIT, Trichy

Dr. V. Anandakrishnan  
Coordinator/Associate Centre Head  
CoE NIT, Trichy

Dr. D. Sriram Kumar  
Centre Head  
CoE NIT, Trichy



**NATIONAL INSTITUTE OF TECHNOLOGY  
TIRUCHIRAPPALLI – 620015  
CENTRE OF EXCELLENCE IN MANUFACTURING**

Certificate No. – NITT/CoEM/2022-23/INT07/21

# Certificate

This is to certify that **VIJAY.D** from **Kamaraj College of Engineering and Technology**, Madurai district, Tamilnadu has participated and successfully completed the course on "**NX CAD - Beginner**" conducted by the Centre of Excellence in Manufacturing, National Institute of Technology, Tiruchirappalli from 26<sup>th</sup> August 2022 to 28<sup>th</sup> August 2022.

Dr.-Ing. M. Duraiselvam  
Coordinator/Dean P&D  
NIT, Trichy

Dr. V. Anandakrishnan  
Coordinator/Associate Centre Head  
CoE NIT, Trichy

Dr. D. Sriram Kumar  
Centre Head  
CoE NIT, Trichy





**NATIONAL INSTITUTE OF TECHNOLOGY  
TIRUCHIRAPPALLI – 620015  
CENTRE OF EXCELLENCE IN MANUFACTURING**

Certificate No. – NITT/CoEM/2022-23/INT07/06

# Certificate

This is to certify that **HARISH.S** from **Kamaraj College of Engineering and Technology**, Madurai district, Tamilnadu has participated and successfully completed the course on "**NX CAD - Beginner**" conducted by the Centre of Excellence in Manufacturing, National Institute of Technology, Tiruchirappalli from 23<sup>rd</sup> August 2022 to 25<sup>th</sup> August 2022.

Dr.-Ing. M. Duraiselvam  
Coordinator/Dean P&D  
NIT, Trichy

Dr. V. Anandakrishnan  
Coordinator/Associate Centre Head  
CoE NIT, Trichy

Dr. D. Sriram Kumar  
Centre Head  
CoE NIT, Trichy



NATIONAL INSTITUTE OF TECHNOLOGY  
TIRUCHIRAPPALLI – 620015  
CENTRE OF EXCELLENCE IN MANUFACTURING

Certificate No. – NITT/CoEM/2022-23/INT07/45

# Certificate

This is to certify that **DHANUSH KUMAR.M** from **Kamaraj College of Engineering and Technology**, Madurai district, Tamilnadu has participated and successfully completed the course on **"NX CAD - Beginner"** conducted by the Centre of Excellence in Manufacturing, National Institute of Technology, Tiruchirappalli from 26<sup>th</sup> August 2022 to 28<sup>th</sup> August 2022.

Dr.-Ing. M. Duraiselvam  
Coordinator/Dean P&D  
NIT, Trichy

Dr. V. Anandkrishnan  
Coordinator/Associate Centre Head  
CoE NIT, Trichy

Dr. D. Sriram Kumar  
Centre Head  
CoE NIT, Trichy



**NATIONAL INSTITUTE OF TECHNOLOGY  
TIRUCHIRAPPALLI – 620015  
CENTRE OF EXCELLENCE IN MANUFACTURING**

Certificate No. – NITT/CoEM/2022-23/INT07/07

# Certificate

This is to certify that **ALPHONSE SAM ANTO.G** from **Kamaraj College of Engineering and Technology**, Madurai district, Tamilnadu has participated and successfully completed the course on **"NX CAD - Beginner"** conducted by the Centre of Excellence in Manufacturing, National Institute of Technology, Tiruchirappalli from 23<sup>rd</sup> August 2022 to 25<sup>th</sup> August 2022.

Dr.-Ing. M. Duraiselvam  
Coordinator/Dean P&D  
NIT, Trichy

Dr. V. Anandkrishnan  
Coordinator/Associate Centre Head  
CoE NIT, Trichy

Dr. D. Sriram Kumar  
Centre Head  
CoE NIT, Trichy



**NATIONAL INSTITUTE OF TECHNOLOGY  
TIRUCHIRAPPALLI – 620015  
CENTRE OF EXCELLENCE IN MANUFACTURING**

Certificate No. – NITT/CoEM/2022-23/INT07/08

# Certificate

This is to certify that **VIGNESH.L** from **Kamaraj College of Engineering and Technology**, Madurai district, Tamilnadu has participated and successfully completed the course on "**NX CAD - Beginner**" conducted by the Centre of Excellence in Manufacturing, National Institute of Technology, Tiruchirappalli from 23<sup>rd</sup> August 2022 to 25<sup>th</sup> August 2022.

Dr.-Ing. M. Duraiselvam  
Coordinator/Dean P&D  
NIT, Trichy

Dr. V. Anandakrishnan  
Coordinator/Associate Centre Head  
CoE NIT, Trichy

Dr. D. Sriram Kumar  
Centre Head  
CoE NIT, Trichy



**NATIONAL INSTITUTE OF TECHNOLOGY  
TIRUCHIRAPPALLI – 620015  
CENTRE OF EXCELLENCE IN MANUFACTURING**

Certificate No. – NITT/CoEM/2022-23/INT07/09

# Certificate

This is to certify that **MANOJ KUMAR.M** from **Kamaraj College of Engineering and Technology**, Madurai district, Tamilnadu has participated and successfully completed the course on **"NX CAD - Beginner"** conducted by the Centre of Excellence in Manufacturing, National Institute of Technology, Tiruchirappalli from 23<sup>rd</sup> August 2022 to 25<sup>th</sup> August 2022.

Dr.-Ing. M. Duraiselvam  
Coordinator/Dean P&D  
NIT, Trichy

Dr. V. Anandakrishnan  
Coordinator/Associate Centre Head  
CoE NIT, Trichy

Dr. D. Sriram Kumar  
Centre Head  
CoE NIT, Trichy



Certificate No. – NITT/CoEM/2022-23/INT07/10

**NATIONAL INSTITUTE OF TECHNOLOGY  
TIRUCHIRAPPALLI – 620015  
CENTRE OF EXCELLENCE IN MANUFACTURING**

# Certificate

This is to certify that **ARULMURUGAN.K** from **Kamaraj College of Engineering and Technology**, Madurai district, Tamilnadu has participated and successfully completed the course on **"NX CAD - Beginner"** conducted by the Centre of Excellence in Manufacturing, National Institute of Technology, Tiruchirappalli from 23<sup>rd</sup> August 2022 to 25<sup>th</sup> August 2022.

Dr.-Ing. M. Duraiselvam  
Coordinator/Dean P&D  
NIT, Trichy

Dr. V. Anandkrishnan  
Coordinator/Associate Centre Head  
CoE NIT, Trichy

Dr. D. Sriram Kumar  
Centre Head  
CoE NIT, Trichy



NATIONAL INSTITUTE OF TECHNOLOGY  
TIRUCHIRAPPALLI – 620015  
CENTRE OF EXCELLENCE IN MANUFACTURING

Certificate No. – NITT/CoEM/2022-23/INT07/11

# Certificate

This is to certify that **NAVANEETHA KRISHNAN.P** from **Kamaraj College of Engineering and Technology**, Madurai district, Tamilnadu has participated and successfully completed the course on **"NX CAD - Beginner"** conducted by the Centre of Excellence in Manufacturing, National Institute of Technology, Tiruchirappalli from 23<sup>rd</sup> August 2022 to 25<sup>th</sup> August 2022.

Dr.-Ing. M. Duraiselvam  
Coordinator/Dean P&D  
NIT, Trichy

Dr. V. Anandakrishnan  
Coordinator/Associate Centre Head  
CoE NIT, Trichy

Dr. D. Sriram Kumar  
Centre Head  
CoE NIT, Trichy



**NATIONAL INSTITUTE OF TECHNOLOGY  
TIRUCHIRAPPALLI – 620015  
CENTRE OF EXCELLENCE IN MANUFACTURING**

Certificate No. – NITT/CoEM/2022-23/INT07/46

# Certificate

This is to certify that **ANANTHA KANNAN.K** from **Kamaraj College of Engineering and Technology**, Madurai district, Tamilnadu has participated and successfully completed the course on **"NX CAD - Beginner"** conducted by the Centre of Excellence in Manufacturing, National Institute of Technology, Tiruchirappalli from 26<sup>th</sup> August 2022 to 28<sup>th</sup> August 2022.

Dr.-Ing. M. Duraiselvam  
Coordinator/Dean P&D  
NIT, Trichy

Dr. V. Anandkrishnan  
Coordinator/Associate Centre Head  
CoE NIT, Trichy

Dr. D. Sriram Kumar  
Centre Head  
CoE NIT, Trichy





Certificate No. – NITT/CoEM/2022-23/INT07/12

**NATIONAL INSTITUTE OF TECHNOLOGY  
TIRUCHIRAPPALLI – 620015  
CENTRE OF EXCELLENCE IN MANUFACTURING**

# Certificate

This is to certify that **JAIDEEP KUMAR.K** from **Kamaraj College of Engineering and Technology**, Madurai district, Tamilnadu has participated and successfully completed the course on **"NX CAD - Beginner"** conducted by the Centre of Excellence in Manufacturing, National Institute of Technology, Tiruchirappalli from 23<sup>rd</sup> August 2022 to 25<sup>th</sup> August 2022.

Dr.-Ing. M. Duraiselvam  
Coordinator/Dean P&D  
NIT, Trichy

Dr. V. Anandakrishnan  
Coordinator/Associate Centre Head  
CoE NIT, Trichy

Dr. D. Sriram Kumar  
Centre Head  
CoE NIT, Trichy



**NATIONAL INSTITUTE OF TECHNOLOGY  
TIRUCHIRAPPALLI – 620015  
CENTRE OF EXCELLENCE IN MANUFACTURING**

Certificate No. – NITT/CoEM/2022-23/INT07/13

# Certificate

This is to certify that **SHYAM.M.DA** from **Kamaraj College of Engineering and Technology**, Madurai district, Tamilnadu has participated and successfully completed the course on **"NX CAD - Beginner"** conducted by the Centre of Excellence in Manufacturing, National Institute of Technology, Tiruchirappalli from 23<sup>rd</sup> August 2022 to 25<sup>th</sup> August 2022.

Dr.-Ing. M. Duraiselvam  
Coordinator/Dean P&D  
NIT, Trichy

Dr. V. Anandakrishnam  
Coordinator/Associate Centre Head  
CoE NIT, Trichy

Dr. D. Sriram Kumar  
Centre Head  
CoE NIT, Trichy



**NATIONAL INSTITUTE OF TECHNOLOGY  
TIRUCHIRAPPALLI – 620015  
CENTRE OF EXCELLENCE IN MANUFACTURING**

Certificate No. – NITT/CoEM/2022-23/INT07/22

# Certificate

This is to certify that **MAREESWARAN.R** from **Kamaraj College of Engineering and Technology**, Madurai district, Tamilnadu has participated and successfully completed the course on **"NX CAD - Beginner"** conducted by the Centre of Excellence in Manufacturing, National Institute of Technology, Tiruchirappalli from 26<sup>th</sup> August 2022 to 28<sup>th</sup> August 2022.

Dr.-Ing. M. Duraiselvam  
Coordinator/Dean P&D  
NIT, Trichy

Dr. V. Anandkrishnan  
Coordinator/Associate Centre Head  
CoE NIT, Trichy

Dr. D. Sriram Kumar  
Centre Head  
CoE NIT, Trichy



**NATIONAL INSTITUTE OF TECHNOLOGY  
TIRUCHIRAPPALLI – 620015  
CENTRE OF EXCELLENCE IN MANUFACTURING**

Certificate No. – NITT/CoEM/2022-23/INT07/14

# Certificate

This is to certify that **JEEVA.K** from **Kamaraj College of Engineering and Technology**, Madurai district, Tamilnadu has participated and successfully completed the course on "**NX CAD - Beginner**" conducted by the Centre of Excellence in Manufacturing, National Institute of Technology, Tiruchirappalli from 23<sup>rd</sup> August 2022 to 25<sup>th</sup> August 2022.

Dr.-Ing. M. Duraiselvam  
Coordinator/Dean P&D  
NIT, Trichy

Dr. V. Anandkrishnan  
Coordinator/Associate Centre Head  
CoE NIT, Trichy

Dr. D. Sriram Kumar  
Centre Head  
CoE NIT, Trichy



NATIONAL INSTITUTE OF TECHNOLOGY  
TIRUCHIRAPPALLI – 620015  
CENTRE OF EXCELLENCE IN MANUFACTURING

Certificate No. – NITT/CoEM/2022-23/INT07/15

# Certificate

This is to certify that **BALAMANIKANDAN.V** from **Kamaraj College of Engineering and Technology**, Madurai district, Tamilnadu has participated and successfully completed the course on **"NX CAD - Beginner"** conducted by the Centre of Excellence in Manufacturing, National Institute of Technology, Tiruchirappalli from 23<sup>rd</sup> August 2022 to 25<sup>th</sup> August 2022.

Dr.-Ing. M. Duraiselvam  
Coordinator/Dean P&D  
NIT, Trichy

Dr. V. Anandakrishnan  
Coordinator/Associate Centre Head  
CoE NIT, Trichy

Dr. D. Sriram Kumar  
Centre Head  
CoE NIT, Trichy



**NATIONAL INSTITUTE OF TECHNOLOGY  
TIRUCHIRAPPALLI – 620015  
CENTRE OF EXCELLENCE IN MANUFACTURING**

Certificate No. – NITT/CoEM/2022-23/INT07/16

# Certificate

This is to certify that **BHARATH.M** from **Kamaraj College of Engineering and Technology**, Madurai district, Tamilnadu has participated and successfully completed the course on "**NX CAD - Beginner**" conducted by the Centre of Excellence in Manufacturing, National Institute of Technology, Tiruchirappalli from 23<sup>rd</sup> August 2022 to 25<sup>th</sup> August 2022.

Dr.-Ing. M. Duraiselvam  
Coordinator/Dean P&D  
NIT, Trichy

Dr. V. Anandakrishnan  
Coordinator/Associate Centre Head  
CoE NIT, Trichy

Dr. D. Sriram Kumar  
Centre Head  
CoE NIT, Trichy



**NATIONAL INSTITUTE OF TECHNOLOGY  
TIRUCHIRAPPALLI – 620015  
CENTRE OF EXCELLENCE IN MANUFACTURING**

Certificate No. – NITT/CoEM/2022-23/INT07/17

# Certificate

This is to certify that **SIVAGURU.U** from **Kamaraj College of Engineering and Technology**, Madurai district, Tamilnadu has participated and successfully completed the course on **"NX CAD - Beginner"** conducted by the Centre of Excellence in Manufacturing, National Institute of Technology, Tiruchirappalli from 23<sup>rd</sup> August 2022 to 25<sup>th</sup> August 2022.

Dr.-Ing. M. Duraiselvam  
Coordinator/Dean P&D  
NIT, Trichy

Dr. V. Anandakrishnan  
Coordinator/Associate Centre Head  
CoE NIT, Trichy

Dr. D. Sriram Kumar  
Centre Head  
CoE NIT, Trichy



**NATIONAL INSTITUTE OF TECHNOLOGY  
TIRUCHIRAPPALLI – 620015  
CENTRE OF EXCELLENCE IN MANUFACTURING**

Certificate No. – NITT/CoEM/2022-23/INT07/23

# Certificate

This is to certify that **SIVARAJ.K** from **Kamaraj College of Engineering and Technology**, Madurai district, Tamilnadu has participated and successfully completed the course on **"NX CAD - Beginner"** conducted by the Centre of Excellence in Manufacturing, National Institute of Technology, Tiruchirappalli from 26<sup>th</sup> August 2022 to 28<sup>th</sup> August 2022.

Dr.-Ing. M. Duraiselvam  
Coordinator/Dean P&D  
NIT, Trichy

Dr. V. Anandakrishnan  
Coordinator/Associate Centre Head  
CoE NIT, Trichy

Dr. D. Sriram Kumar  
Centre Head  
CoE NIT, Trichy





**NATIONAL INSTITUTE OF TECHNOLOGY  
TIRUCHIRAPPALLI – 620015  
CENTRE OF EXCELLENCE IN MANUFACTURING**

Certificate No. – NITT/CoEM/2022-23/INT07/18

# Certificate

This is to certify that **SHYAM GANESH.V** from **Kamaraj College of Engineering and Technology**, Madurai district, Tamilnadu has participated and successfully completed the course on **"NX CAD - Beginner"** conducted by the Centre of Excellence in Manufacturing, National Institute of Technology, Tiruchirappalli from 23<sup>rd</sup> August 2022 to 25<sup>th</sup> August 2022.

Dr.-Ing. M. Duraiselvam  
Coordinator/Dean P&D  
NIT, Trichy

Dr. V. Anandakrishnan  
Coordinator/Associate Centre Head  
CoE NIT, Trichy

Dr. D. Sriram Kumar  
Centre Head  
CoE NIT, Trichy



NATIONAL INSTITUTE OF TECHNOLOGY  
TIRUCHIRAPPALLI – 620015  
**CENTRE OF EXCELLENCE IN MANUFACTURING**

Certificate No. – NITT/CoEM/2022-23/INT07/19

# Certificate

This is to certify that **SHANMUGAPRIYAN.A.G** from **Kamaraj College of Engineering and Technology**, Madurai district, Tamilnadu has participated and successfully completed the course on **"NX CAD - Beginner"** conducted by the Centre of Excellence in Manufacturing, National Institute of Technology, Tiruchirappalli from 23<sup>rd</sup> August 2022 to 25<sup>th</sup> August 2022.

Dr.-Ing. M. Duraiselvam  
Coordinator/Dean P&D  
NIT, Trichy

Dr. V. Anandakrishnan  
Coordinator/Associate Centre Head  
COE NIT, Trichy

Dr. D. Sri Ram Kumar  
Centre Head  
COE NIT, Trichy



NATIONAL INSTITUTE OF TECHNOLOGY  
TIRUCHIRAPPALLI – 620015  
**CENTRE OF EXCELLENCE IN MANUFACTURING**

Certificate No. – NITT/CoEM/2022-23/INT07/24

# Certificate

This is to certify that **KALAI SELVAN.R** from **Kamaraj College of Engineering and Technology**, Madurai district, Tamilnadu has participated and successfully completed the course on **“NX CAD - Beginner”** conducted by the Centre of Excellence in Manufacturing, National Institute of Technology, Tiruchirappalli from 26<sup>th</sup> August 2022 to 28<sup>th</sup> August 2022.

Dr.-Ing. M. Duraiselvam  
Coordinator/Dean P&D  
NIT, Trichy

Dr. V. Anandakrishnan  
Coordinator/Associate Centre Head  
COE NIT, Trichy

Dr. D. Sriram Kumar  
Centre Head  
COE NIT, Trichy



NATIONAL INSTITUTE OF TECHNOLOGY  
TIRUCHIRAPPALLI – 620015  
**CENTRE OF EXCELLENCE IN MANUFACTURING**

Certificate No. – NITT/CoEM/2022-23/INT07/25

# Certificate

This is to certify that **HARIHARAN.N** from **Kamaraj College of Engineering and Technology**, Madurai district, Tamilnadu has participated and successfully completed the course on **"NX CAD - Beginner"** conducted by the Centre of Excellence in Manufacturing, National Institute of Technology, Tiruchirappalli from 26<sup>th</sup> August 2022 to 28<sup>th</sup> August 2022.

Dr.-Ing. M. Duraiselvam  
Coordinator/Dean P&D  
NIT, Trichy

Dr. V. Anandakrishnan  
Coordinator/Associate Centre Head  
COE NIT, Trichy

Dr. D. Sriram Kumar  
Centre Head  
COE NIT, Trichy



NATIONAL INSTITUTE OF TECHNOLOGY  
TIRUCHIRAPPALLI – 620015  
**CENTRE OF EXCELLENCE IN MANUFACTURING**

Certificate No. – NITT/CoEM/2022-23/INT07/26

# Certificate

This is to certify that **THANGARAJ.T** from **Kamaraj College of Engineering and Technology**, Madurai district, Tamilnadu has participated and successfully completed the course on **"NX CAD - Beginner"** conducted by the Centre of Excellence in Manufacturing, National Institute of Technology, Tiruchirappalli from 26<sup>th</sup> August 2022 to 28<sup>th</sup> August 2022.

Dr.-Ing. M. Duraiselvam  
Coordinator/Dean P&D  
NIT, Trichy

Dr. V. Anandakrishnan  
Coordinator/Associate Centre Head  
CoE NIT, Trichy

Dr. D. Sriram Kumar  
Centre Head  
CoE NIT, Trichy



NATIONAL INSTITUTE OF TECHNOLOGY  
TIRUCHIRAPPALLI – 620015  
**CENTRE OF EXCELLENCE IN MANUFACTURING**

Certificate No. – NITT/CoEM/2022-23/INT07/27

# Certificate

This is to certify that **HARISURIYA.M** from **Kamaraj College of Engineering and Technology**, Madurai district, Tamilnadu has participated and successfully completed the course on **“NX CAD - Beginner”** conducted by the Centre of Excellence in Manufacturing, National Institute of Technology, Tiruchirappalli from 26<sup>th</sup> August 2022 to 28<sup>th</sup> August 2022.

Dr.-Ing. M. Duraiselvam  
Coordinator/Dean P&D  
NIT, Trichy

Dr. V. Anandakrishnan  
Coordinator/Associate Centre Head  
CoE NIT, Trichy

Dr. D. Sriram Kumar  
Centre Head  
CoE NIT, Trichy



**NATIONAL INSTITUTE OF TECHNOLOGY  
TIRUCHIRAPPALLI – 620015  
CENTRE OF EXCELLENCE IN MANUFACTURING**

Certificate No. – NITT/CoEM/2022-23/INT07/28

# Certificate

This is to certify that **PREM KUMAR.V.V** from **Kamaraj College of Engineering and Technology**, Madurai district, Tamilnadu has participated and successfully completed the course on **“NX CAD - Beginner”** conducted by the Centre of Excellence in Manufacturing, National Institute of Technology, Tiruchirappalli from 26<sup>th</sup> August 2022 to 28<sup>th</sup> August 2022.

Dr.-Ing. M. Duraiselvam  
Coordinator/Dean P&D  
NIT, Trichy

Dr. V. Anandakrishnan  
Coordinator/Associate Centre Head  
CoE NIT, Trichy

Dr. D. Sriram Kumar  
Centre Head  
CoE NIT, Trichy



NATIONAL INSTITUTE OF TECHNOLOGY  
TIRUCHIRAPPALLI – 620015  
**CENTRE OF EXCELLENCE IN MANUFACTURING**

Certificate No. – NITT/CoEM/2022-23/INT07/29

# Certificate

This is to certify that **PRAVEEN.C** from **Kamaraj College of Engineering and Technology**,  
Madurai district, Tamilnadu has participated and successfully completed the course on "**NX  
CAD - Beginner**" conducted by the Centre of Excellence in Manufacturing, National Institute  
of Technology, Tiruchirappalli from 26<sup>th</sup> August 2022 to 28<sup>th</sup> August 2022.

Dr.-Ing. M. Duraiselvam  
Coordinator/Dean P&D  
NIT, Trichy

Dr. V. Anandakrishnan  
Coordinator/Associate Centre Head  
COE NIT, Trichy

Dr. D. Sriram Kumar  
Centre Head  
COE NIT, Trichy





NATIONAL INSTITUTE OF TECHNOLOGY  
TIRUCHIRAPPALLI – 620015  
**CENTRE OF EXCELLENCE IN MANUFACTURING**

Certificate No. – NITT/CoEM/2022-23/INT07/30

# Certificate

This is to certify that **SILAMPARASAN.P** from **Kamaraj College of Engineering and Technology**, Madurai district, Tamilnadu has participated and successfully completed the course on “**NX CAD - Beginner**” conducted by the Centre of Excellence in Manufacturing, National Institute of Technology, Tiruchirappalli from 26<sup>th</sup> August 2022 to 28<sup>th</sup> August 2022.

Dr.-Ing. M. Duraiselvam  
Coordinator/Dean P&D  
NIT, Trichy

Dr. V. Anandakrishnan  
Coordinator/Associate Centre Head  
COE NIT, Trichy

Dr. D. Sriram Kumar  
Centre Head  
COE NIT, Trichy



NATIONAL INSTITUTE OF TECHNOLOGY  
TIRUCHIRAPPALLI – 620015  
**CENTRE OF EXCELLENCE IN MANUFACTURING**

Certificate No. – NITT/CoEM/2022-23/INT07/31

# Certificate

This is to certify that **SATHISHKUMAR.D** from **Kamaraj College of Engineering and Technology**, Madurai district, Tamilnadu has participated and successfully completed the course on **"NX CAD - Beginner"** conducted by the Centre of Excellence in Manufacturing, National Institute of Technology, Tiruchirappalli from 26<sup>th</sup> August 2022 to 28<sup>th</sup> August 2022.

Dr.-Ing. M. Duraiselvam  
Coordinator/Dean P&D  
NIT, Trichy

Dr. V. Anandakrishnan  
Coordinator/Associate Centre Head  
CoE NIT, Trichy

Dr. D. Sriram Kumar  
Centre Head  
CoE NIT, Trichy



NATIONAL INSTITUTE OF TECHNOLOGY  
TIRUCHIRAPPALLI – 620015  
**CENTRE OF EXCELLENCE IN MANUFACTURING**

Certificate No. – NITT/CoEM/2022-23/INT07/32

# Certificate

This is to certify that **KARTHIGAI SELVAN.R** from **Kamaraj College of Engineering and Technology**, Madurai district, Tamilnadu has participated and successfully completed the course on **“NX CAD - Beginner”** conducted by the Centre of Excellence in Manufacturing, National Institute of Technology, Tiruchirappalli from 26<sup>th</sup> August 2022 to 28<sup>th</sup> August 2022.

Dr.-Ing. M. Duraiselvam  
Coordinator/Dean P&D  
NIT, Trichy

Dr. V. Anandakrishnan  
Coordinator/Associate Centre Head  
CoE NIT, Trichy

Dr. D. Sriram Kumar  
Centre Head  
CoE NIT, Trichy



NATIONAL INSTITUTE OF TECHNOLOGY  
TIRUCHIRAPPALLI – 620015  
**CENTRE OF EXCELLENCE IN MANUFACTURING**

Certificate No. – NITT/CoEM/2022-23/INT07/33

# Certificate

This is to certify that **THIRUMALAI RAJ.K** from **Kamaraj College of Engineering and Technology**, Madurai district, Tamilnadu has participated and successfully completed the course on **"NX CAD - Beginner"** conducted by the Centre of Excellence in Manufacturing, National Institute of Technology, Tiruchirappalli from 26<sup>th</sup> August 2022 to 28<sup>th</sup> August 2022.

Dr.-Ing. M. Duraiselvam  
Coordinator/Dean P&D  
NIT, Trichy

Dr. V. Anandakrishnan  
Coordinator/Associate Centre Head  
COE NIT, Trichy

Dr. D. Sriram Kumar  
Centre Head  
COE NIT, Trichy



NATIONAL INSTITUTE OF TECHNOLOGY  
TIRUCHIRAPPALLI – 620015  
**CENTRE OF EXCELLENCE IN MANUFACTURING**

Certificate No. – NITT/CoEM/2022-23/INT07/20

# Certificate

This is to certify that **NAGENDRAN,J** from **Kamaraj College of Engineering and Technology**, Madurai district, Tamilnadu has participated and successfully completed the course on **"NX CAD - Beginner"** conducted by the Centre of Excellence in Manufacturing, National Institute of Technology, Tiruchirappalli from 23<sup>rd</sup> August 2022 to 25<sup>th</sup> August 2022.

Dr.-Ing. M. Duraiselvam  
Coordinator/Dean P&D  
NIT, Trichy

Dr. V. Anandakrishnan  
Coordinator/Associate Centre Head  
COE NIT, Trichy

Dr. D. Sriram Kumar  
Centre Head  
COE NIT, Trichy



NATIONAL INSTITUTE OF TECHNOLOGY  
TIRUCHIRAPPALLI – 620015  
**CENTRE OF EXCELLENCE IN MANUFACTURING**

Certificate No. – NITT/CoEM/2022-23/INT07/34

# Certificate

This is to certify that GOKULAKRISHNAN.E from **Kamaraj College of Engineering and Technology**, Madurai district, Tamilnadu has participated and successfully completed the course on **“NX CAD - Beginner”** conducted by the Centre of Excellence in Manufacturing, National Institute of Technology, Tiruchirappalli from 26<sup>th</sup> August 2022 to 28<sup>th</sup> August 2022.

Dr.-Ing. M. Duraiselvam  
Coordinator/Dean P&D  
NIT, Trichy

Dr. V. Anandakrishnan  
Coordinator/Associate Centre Head  
CoE NIT, Trichy

Dr. D. Sriram Kumar  
Centre Head  
CoE NIT, Trichy



NATIONAL INSTITUTE OF TECHNOLOGY  
TIRUCHIRAPPALLI – 620015  
**CENTRE OF EXCELLENCE IN MANUFACTURING**

Certificate No. – NITT/CoEM/2022-23/INT07/35

# Certificate

This is to certify that **SREE PRABHU.A** from **Kamaraj College of Engineering and Technology**, Madurai district, Tamilnadu has participated and successfully completed the course on **"NX CAD - Beginner"** conducted by the Centre of Excellence in Manufacturing, National Institute of Technology, Tiruchirappalli from 26<sup>th</sup> August 2022 to 28<sup>th</sup> August 2022.

Dr.-Ing. M. Duraiselvam  
Coordinator/Dean P&D  
NIT, Trichy

Dr. V. Anandakrishnan  
Coordinator/Associate Centre Head  
CoE NIT, Trichy

Dr. D. Sriram Kumar  
Centre Head  
CoE NIT, Trichy



NATIONAL INSTITUTE OF TECHNOLOGY  
TIRUCHIRAPPALLI – 620015  
**CENTRE OF EXCELLENCE IN MANUFACTURING**

Certificate No. – NITT/CoEM/2022-23/INT07/36

# Certificate

This is to certify that **SARAVANA KUMAR.C** from **Kamaraj College of Engineering and Technology**, Madurai district, Tamilnadu has participated and successfully completed the course on **"NX CAD - Beginner"** conducted by the Centre of Excellence in Manufacturing, National Institute of Technology, Tiruchirappalli from 26<sup>th</sup> August 2022 to 28<sup>th</sup> August 2022.

Dr.-Ing. M. Duraiselvam  
Coordinator/Dean P&D  
NIT, Trichy

Dr. V. Anandakrishnan  
Coordinator/Associate Centre Head  
COE NIT, Trichy

Dr. D. Sriram Kumar  
Centre Head  
COE NIT, Trichy





NATIONAL INSTITUTE OF TECHNOLOGY  
TIRUCHIRAPPALLI – 620015  
**CENTRE OF EXCELLENCE IN MANUFACTURING**

Certificate No. – NITT/CoEM/2022-23/INT07/37

# Certificate

This is to certify that **SABARIS.H.G** from **Kamaraj College of Engineering and Technology**, Madurai district, Tamilnadu has participated and successfully completed the course on **"NX CAD - Beginner"** conducted by the Centre of Excellence in Manufacturing, National Institute of Technology, Tiruchirappalli from 26<sup>th</sup> August 2022 to 28<sup>th</sup> August 2022.

Dr.-Ing. M. Duraiselvam  
Coordinator/Dean P&D  
NIT, Trichy

Dr. V. Anandakrishnan  
Coordinator/Associate Centre Head  
COE NIT, Trichy

Dr. D. Sriram Kumar  
Centre Head  
COE NIT, Trichy



NATIONAL INSTITUTE OF TECHNOLOGY  
TIRUCHIRAPPALLI – 620015  
**CENTRE OF EXCELLENCE IN MANUFACTURING**

Certificate No. – NITT/CoEM/2022-23/INT07/38

# Certificate

This is to certify that **KESAVAN.J** from **Kamaraj College of Engineering and Technology**, Madurai district, Tamilnadu has participated and successfully completed the course on "**CAD - Beginner**" conducted by the Centre of Excellence in Manufacturing, National Institute of Technology, Tiruchirappalli from 26<sup>th</sup> August 2022 to 28<sup>th</sup> August 2022.

Dr.-Ing. M. Duraiselvam  
Coordinator/Dean P&D  
NIT, Trichy

Dr. V. Anandakrishnan  
Coordinator/Associate Centre Head  
COE NIT, Trichy

Dr. D. Sriram Kumar  
Centre Head  
COE NIT, Trichy



NATIONAL INSTITUTE OF TECHNOLOGY  
TIRUCHIRAPPALLI – 620015  
**CENTRE OF EXCELLENCE IN MANUFACTURING**

Certificate No. – NITT/CoEM/2022-23/INT07/39

# Certificate

This is to certify that RAJAGURU.C from **Kamaraj College of Engineering and Technology**, Madurai district, Tamilnadu has participated and successfully completed the course on **"NX CAD - Beginner"** conducted by the Centre of Excellence in Manufacturing, National Institute of Technology, Tiruchirappalli from 26<sup>th</sup> August 2022 to 28<sup>th</sup> August 2022.

Dr.-Ing. M. Duraiselvam  
Coordinator/Dean P&D  
NIT, Trichy

Dr. V. Anandakrishnan  
Coordinator/Associate Centre Head  
CoE NIT, Trichy

Dr. D. Sriram Kumar  
Centre Head  
CoE NIT, Trichy



NATIONAL INSTITUTE OF TECHNOLOGY  
TIRUCHIRAPPALLI – 620015  
CENTRE OF EXCELLENCE IN MANUFACTURING

Certificate No. – NITT/CoEM/2022-23/INT07/40

# Certificate

This is to certify that CHANDRA KUMAR.G from **Kamaraj College of Engineering and Technology**, Madurai district, Tamilnadu has participated and successfully completed the course on **“NX CAD - Beginner”** conducted by the Centre of Excellence in Manufacturing, National Institute of Technology, Tiruchirappalli from 26<sup>th</sup> August 2022 to 28<sup>th</sup> August 2022.

Dr.-Ing. M. Duraiselvam  
Coordinator/Dean P&D  
NIT, Trichy

Dr. V. Anandakrishnan  
Coordinator/Associate Centre Head  
CoE NIT, Trichy

Dr. D. Sriram Kumar  
Centre Head  
CoE NIT, Trichy



NATIONAL INSTITUTE OF TECHNOLOGY  
TIRUCHIRAPPALLI – 620015  
**CENTRE OF EXCELLENCE IN MANUFACTURING**

Certificate No. – NITT/CoEM/2022-23/INT07/41

# Certificate

This is to certify that **AKASH.A** from **Kamaraj College of Engineering and Technology**,  
Madurai district, Tamilnadu has participated and successfully completed the course on "**NX  
CAD - Beginner**" conducted by the Centre of Excellence in Manufacturing, National Institute  
of Technology, Tiruchirappalli from 26<sup>th</sup> August 2022 to 28<sup>th</sup> August 2022.

Dr.-Ing. M. Duraiselvam  
Coordinator/Dean P&D  
NIT, Trichy

Dr. V. Anandakrishnan  
Coordinator/Associate Centre Head  
CoE NIT, Trichy

Dr. D. Sriram Kumar  
Centre Head  
CoE NIT, Trichy



NATIONAL INSTITUTE OF TECHNOLOGY  
TIRUCHIRAPPALLI – 620015  
**CENTRE OF EXCELLENCE IN MANUFACTURING**

Certificate No. – NITT/CoEM/2022-23/INT07/42

# Certificate

This is to certify that **SUBRAMANIAN.P** from **Kamaraj College of Engineering and Technology**, Madurai district, Tamilnadu has participated and successfully completed the course on **“NX CAD - Beginner”** conducted by the Centre of Excellence in Manufacturing, National Institute of Technology, Tiruchirappalli from 26<sup>th</sup> August 2022 to 28<sup>th</sup> August 2022.

Dr.-Ing. M. Duraiselvam  
Coordinator/Dean P&D  
NIT, Trichy

Dr. V. Anandakrishnan  
Coordinator/Associate Centre Head  
COE NIT, Trichy

Dr. D. Sriram Kumar  
Centre Head  
COE NIT, Trichy



NATIONAL INSTITUTE OF TECHNOLOGY  
TIRUCHIRAPPALLI – 620015  
**CENTRE OF EXCELLENCE IN MANUFACTURING**

Certificate No. – NITT/CoEM/2022-23/INT07/43

# Certificate

This is to certify that **ROHIT VISHNU.K** from **Kamaraj College of Engineering and Technology**, Madurai district, Tamilnadu has participated and successfully completed the course on "**NX CAD - Beginner**" conducted by the Centre of Excellence in Manufacturing, National Institute of Technology, Tiruchirappalli from 26<sup>th</sup> August 2022 to 28<sup>th</sup> August 2022.

Dr.-Ing. M. Duraiselvam  
Coordinator/Dean P&D  
NIT, Trichy

Dr. V. Anandakrishnan  
Coordinator/Associate Centre Head  
CoE NIT, Trichy

Dr. D. Sriram Kumar  
Centre Head  
CoE NIT, Trichy



**NATIONAL INSTITUTE OF TECHNOLOGY  
TIRUCHIRAPPALLI – 620015  
CENTRE OF EXCELLENCE IN MANUFACTURING**

Certificate No. – NITT/CoEM/2022-23/INT07/44

# Certificate

This is to certify that **AKILAN KARUPPAIAH.P** from **Kamaraj College of Engineering and Technology**, Madurai district, Tamilnadu has participated and successfully completed the course on **"NX CAD - Beginner"** conducted by the Centre of Excellence in Manufacturing, National Institute of Technology, Tiruchirappalli from 26<sup>th</sup> August 2022 to 28<sup>th</sup> August 2022.

Dr.-Ing. M. Duraiselvam  
Coordinator/Dean P&D  
NIT, Trichy

Dr. V. Anandakrishnan  
Coordinator/Associate Centre Head  
COE NIT, Trichy

Dr. D. Sriram Kumar  
Centre Head  
COE NIT, Trichy



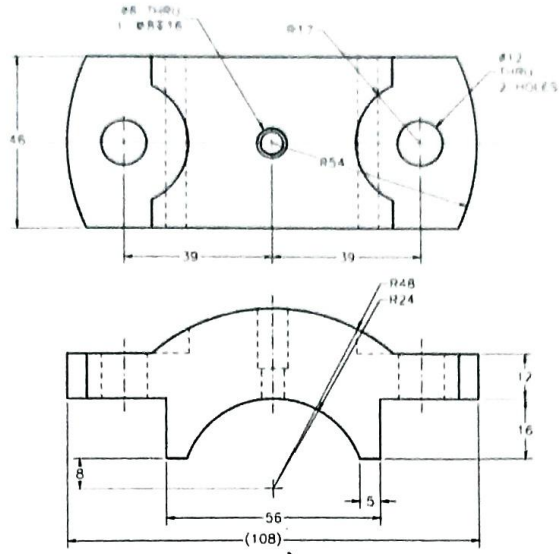

Figure 3 Views and dimensions of the Cap

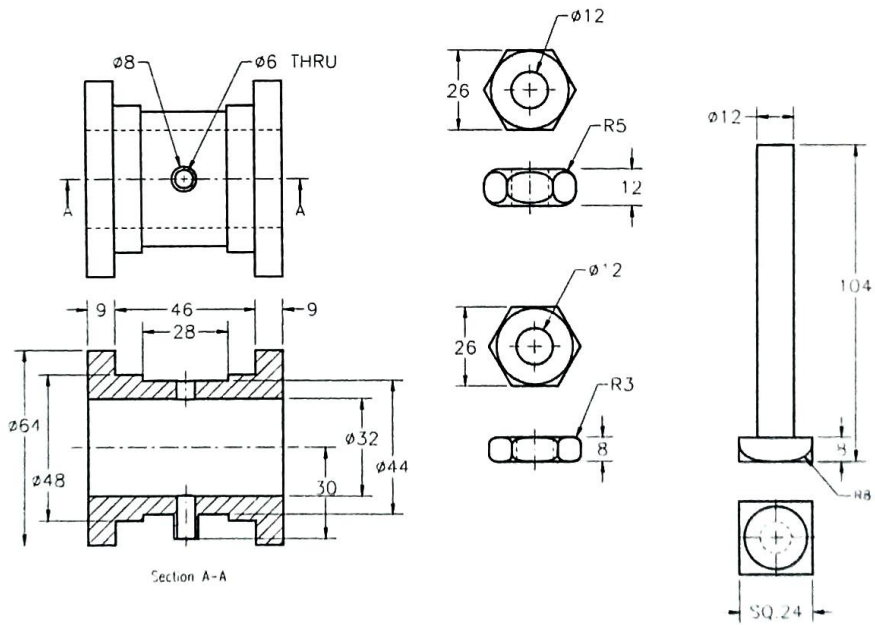

Figure 4 Views and dimensions of Brasses, Nut, Lock Nut, and Bolt

### Plummer Block Assembly

In this project, you will create the components of the Plummer Block assembly, as shown in Figure 1 and then assemble them. The dimensions of the components are given in Figures 2 through 4.

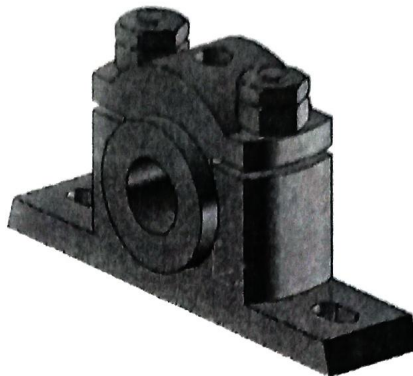

Figure 1 The Plummer Block assembly

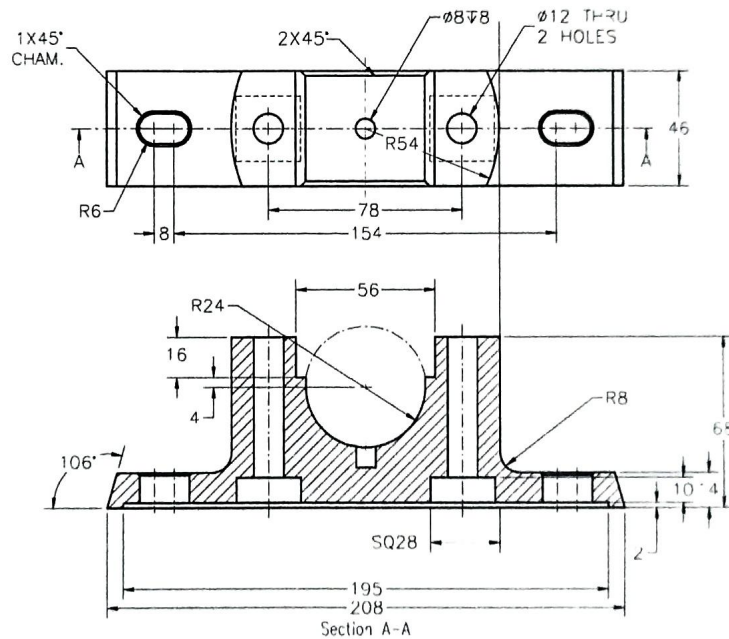

Figure 2 Views and dimensions of the Casting

## Department of Mechanical Engineering

Title of the Program : Value Added Course on "NX-CAD"

Date: 23.08.2022 to 28.08.2022

Participants : III year

Software used : NX - CAD

Conducted by : COE in Manufacturing, NIT – Trichy

Venue : NIT - CAMPUS

Attendance report - Batch I

S.No	Batch	Full Name	Register NO	23.08.2022	24.08.2022	25.08.2022
1	I	SAKTHIVEL.K	920420UME001	Present	Present	Present
2	I	RAHUL.K	920420UME002	Present	Present	Present
3	I	LOGESH.A	920420UME003	Present	Present	Present
4	I	RAJA SRINIVAS.M	920420UME004	Present	Present	Present
5	I	SANTHOSH.V	920420UME005	Present	Present	Present
6	I	HARISH.S	920420UME007	Present	Present	Present
7	I	ALPHONSE SAM ANTO.G	920420UME009	Present	Present	Present
8	I	SHANMUGASUNDARAM.M	920420UME010	Absent	Absent	Absent
9	I	VIGNESH.L	920420UME011	Present	Present	Present
10	I	MANOJ KUMAR.M	920420UME012	Present	Present	Present
11	I	ARULMURUGAN.K	920420UME013	Present	Present	Present
12	I	NAVANEETHA KRISHNAN.P	920420UME014	Present	Present	Present
13	I	JAIDEEP KUMAR.K	920420UME016	Present	Present	Present
14	I	SHYAM.M.DA	920420UME017	Present	Present	Present
15	I	JEEVA.K	920420UME019	Present	Present	Present
16	I	BALAMANIKANDAN.V	920420UME020	Present	Present	Present
17	I	BHARATH.M	920420UME021	Present	Present	Present
18	I	SAIKISHORE.K	920420UME022	Absent	Absent	Absent
19	I	SIVAGURU.U	920420UME023	Present	Present	Present
20	I	SHYAM GANESH.V	920420UME025	Present	Present	Present
21	I	SHANMUGAPRIYAN.A.G	920420UME026	Present	Present	Present
22	I	NAGENDRAN.J	920420UME038	Present	Present	Present

  
Coordinators  
HoD/Mech

## Department of Mechanical Engineering

Title of the Program : Value Added Course on "NX-CAD"

Date: 23.08.2022 to 28.08.2022

Participants : III year

Software used : NX - CAD

Conducted by : COE in Manufacturing, NIT – Trichy

Venue : NIT - CAMPUS

Attendance report - Batch II

S.No	Batch	Full Name	Register NO	26.08.2022	27.08.2022	28.08.2022
1	II	DHANUSH KUMAR.M	920420UME008	Present	Present	Present
2	II	ANANTHA KANNAN.K	920420UME015	Present	Present	Present
3	II	VIJAY.D	920420UME006	Present	Present	Present
4	II	MAREESWARAN.R	920420UME018	Present	Present	Present
5	II	SIVARAJ.K	920420UME024	Present	Present	Present
6	II	KALAI SELVAN.R	920420UME027	Present	Present	Present
7	II	HARIHARAN.N	920420UME028	Present	Present	Present
8	II	THANGARAJ.T	920420UME029	Present	Present	Present
9	II	HARISURIYA.M	920420UME030	Present	Present	Present
10	II	PREM KUMAR.V.V	920420UME031	Present	Present	Present
11	II	PRAVEEN.C	920420UME032	Present	Present	Present
12	II	SILAMPARASAN.P	920420UME033	Present	Present	Present
13	II	SATHISHKUMAR.D	920420UME034	Present	Present	Present
14	II	KARTHIGAI SELVAN.R	920420UME036	Present	Present	Present
15	II	THIRUMALAI RAJ.K	920420UME037	Present	Present	Present
16	II	GOKULAKRISHNAN.E	920420UME039	Present	Present	Present
17	II	SREE PRABHU.A	920420UME040	Present	Present	Present
18	II	SARAVANA KUMAR.C	920420UME041	Present	Present	Present
19	II	SABARIS.H.G	920420UME043	Present	Present	Present
20	II	KESAVAN.J	920420UME044	Present	Present	Present
21	II	RAJAGURU.C	920420UME045	Present	Present	Present
22	II	CHANDRA KUMAR.G	920420UME046	Present	Present	Present
23	II	AKASH.A	920420UME047	Present	Present	Present
24	II	SUBRAMANIAN.P	920420UME048	Present	Present	Present
25	II	ROHIT VISHNU.K	920420UME049	Present	Present	Present
26	II	AKILAN KARUPPAIAH.P	920420UME050	Present	Present	Present

N. S. R. S. S.  
CoordinatorsR. S. S.  
HoD/Mech

## Department of Mechanical Engineering

Title of the Program : Value Added Course on "NX-CAD"

Date: 23.08.2022 to 28.08.2022

Participants : III year

Software used : NX - CAD

Conducted by : COE in Manufacturing, NIT - Trichy

Venue : NIT - CAMPUS

### Attendance report - Batch I

S.No	Batch	Full Name	Register NO	23.08.2022	24.08.2022	25.08.2022
1	1	SAKTHIVEL.K	920420UME001	K. Sakthivel	K. Sakthivel	K. Sakthivel
2	1	RAHUL.K	920420UME002	K. Rah	K. Rah	K. Rah
3	1	LOGESH.A	920420UME003	A. Logesh	A. Logesh	A. Logesh
4	1	RAJA SRINIVAS.M	920420UME004	M. Raj	M. Raj	M. Raj
5	1	SANTHOSH.V	920420UME005	J. Sant	J. Sant	J. Sant
6	1	HARISH.S	920420UME007	S. Harish	S. Harish	S. Harish
7	1	ALPHONSE SAM ANTO.G	920420UME009	S. Anto	S. Anto	S. Anto
8	1	SHANMUGASUNDARAM.M	920420UME010	Absent	Absent	Absent
9	1	VIGNESH.L	920420UME011	L. Vign	L. Vign	L. Vign
10	1	MANOJ KUMAR.M	920420UME012	M. Manoj	M. Manoj	M. Manoj
11	1	ARULMURUGAN.K	920420UME013	K. Arul	K. Arul	K. Arul
12	1	NAVANEETHA KRISHNAN.P	920420UME014	N. Navaneetha	N. Navaneetha	N. Navaneetha
13	1	JAIDEEP KUMAR.K	920420UME016	J. Jaideep	J. Jaideep	J. Jaideep
14	1	SHYAM.M.DA	920420UME017	U. A. Shyam	U. A. Shyam	U. A. Shyam
15	1	JEEVA.K	920420UME019	O. Jeeva	O. Jeeva	O. Jeeva
16	1	BALAMANIKANDAN.V	920420UME020	V. Balamanikandan	V. Balamanikandan	V. Balamanikandan
17	1	BHARATH.M	920420UME021	M. Bharath	M. Bharath	M. Bharath
18	1	SAIKISHORE.K	920420UME022	Absent	Absent	Absent
19	1	SIVAGURU.U	920420UME023	S. Sivaguru	S. Sivaguru	S. Sivaguru
20	1	SHYAM GANESH.V	920420UME025	S. Shyam	S. Shyam	S. Shyam
21	1	SHANMUGAPRIYAN.A.G	920420UME026	J. Shanmugapriyan	J. Shanmugapriyan	J. Shanmugapriyan
22	1	NAGENDRAN.J	920420UME038	J. Nagendran	J. Nagendran	J. Nagendran

N.R.  
 Coordinators

S.S. Sundaram  
 HoD/Mech

## Department of Mechanical Engineering

Title of the Program : Value Added Course on "NX-CAD"

Date: 23.08.2022 to 28.08.2022

Participants : IIII year

Software used : NX - CAD

Conducted by : COE in Manufacturing, NIT – Trichy

Venue : NIT - CAMPUS

### Attendance report - Batch II

S.No	Batch	Full Name	Register NO	26.08.2022	27.08.2022	28.08.2022
1	II	DHANUSH KUMAR.M	920420UME008	M.D.Kaly	M.D.Kaly	M.D.Kaly
2	II	ANANTHA KANNAN.K	920420UME015	K.A.K	K.A.K	K.A.K
3	II	VIJAY.D	920420UME006	D.V	D.V	D.V
4	II	MAREESWARAN.R	920420UME018	R.Mareeswar	R.Mareeswar	R.Mareeswar
5	II	SIVARAJ.K	920420UME024	K.Siv	K.Siv	K.Siv
6	II	KALAI SELVAN.R	920420UME027	R.K.S	R.K.S	R.K.S
7	II	HARIHARAN.N	920420UME028	N.Hari	N.Hari	N.Hari
8	II	THANGARAJ.T	920420UME029	T.Thang	T.Thang	T.Thang
9	II	HARISURIYA.M	920420UME030	M.Hari	M.Hari	M.Hari
10	II	PREM KUMAR.V.V	920420UME031	V.V.Prem	V.V.Prem	V.V.Prem
11	II	PRAVEEN.C	920420UME032	C.P	C.P	C.P
12	II	SILAMPARASAN.P	920420UME033	P.Silamp	P.Silamp	P.Silamp
13	II	SATHISHKUMAR.D	920420UME034	D.Sathish	D.Sathish	D.Sathish
14	II	KARTHIGAI SELVAN.R	920420UME036	R.Karthigai	R.Karthigai	R.Karthigai
15	II	THIRUMALAI RAJ.K	920420UME037	K.Thirumalai	K.Thirumalai	K.Thirumalai
16	II	GOKULAKRISHNAN.E	920420UME039	E.Gokul	E.Gokul	E.Gokul
17	II	SREE PRABHU.A	920420UME040	A.Sree Prabh	A.Sree Prabh	A.Sree Prabh
18	II	SARAVANA KUMAR.C	920420UME041	C.Sarava	C.Sarava	C.Sarava
19	II	SABARIS.H.G	920420UME043	H.G.Sabar	H.G.Sabar	H.G.Sabar
20	II	KESAVAN.J	920420UME044	J.Kesava	J.Kesava	J.Kesava
21	II	RAJAGURU.C	920420UME045	C.Rajagu	C.Rajagu	C.Rajagu
22	II	CHANDRA KUMAR.G	920420UME046	G.Chandra	G.Chandra	G.Chandra
23	II	AKASH.A	920420UME047	A.Akash	A.Akash	A.Akash
24	II	SUBRAMANIAN.P	920420UME048	P.Subrama	P.Subrama	P.Subrama
25	II	ROHIT VISHNU.K	920420UME049	K.Rohit	K.Rohit	K.Rohit
26	II	AKILAN KARUPPAIAH.P	920420UME050	P.Akila	P.Akila	P.Akila

  
 Coordinators

  
 HoD/Mech

**CENTRE OF EXCELLENCE IN MANUFACTURING**  
**NATIONAL INSTITUTE OF TECHNOLOGY TIRUCHIRAPPALLI**  
 Internship for Kamaraj college of Engineering and Technology  
 23<sup>rd</sup> August – 28<sup>th</sup> August 2022  
 Assessment for Batch 2

Sl.No	Reg No.	Student Name	Sketching	Modelling	Assembly	Drafting	Completion	Overall
1	920420UME006	VIJAY.D	5	5	5	5	2	22
2	920420UME018	MAREESWARAN.R	5	5	5	4	2	21
3	920420UME024	SIVARAJ.K	4	4	4	4	3	20
4	920420UME027	KAJAI SELVAN.R	5	4	4	3	3	20
5	920420UME028	HARIHARAN.N	5	5	3	4	2	19
6	920420UME029	THANGARAJ.T	5	4	4	4	4	21
7	920420UME030	HARISURIYA.M	5	5	4	4	4	22
8	920420UME031	PREM KUMAR.V.V	5	5	4	4	2	20
9	920420UME032	PRAVEEN.C	5	5	4	4	2	20
10	920420UME033	SILAMPARASAN.P	5	5	4	4	3	21
11	920420UME034	SATHISHKUMAR.D	5	5	5	5	4	24
12	920420UME036	KARTHIGAI SELVAN.R	5	5	4	4	3	21
13	920420UME037	THIRUMALAI RAJ.K	5	5	4	4	3	21
14	920420UME039	GOKULAKRISHNAN.E	5	5	5	5	4	24
15	920420UME040	SREE PRABHU.A	5	5	4	4	3	21
16	920420UME041	SARAVANA KUMAR.C	5	5	4	3	2	19
17	920420UME043	SABARIS.H.G	5	5	5	5	3	23
18	920420UME044	KESAVAN.J	5	5	5	5	3	23
19	920420UME045	RAJAGURU.C	5	5	5	4	3	22
20	920420UME046	CHANDRA KUMAR.G	5	5	4	4	2	20
21	920420UME047	AKASH.A	5	5	4	4	2	20
22	920420UME048	SUBRAMANIAN.P	5	4	4	4	2	19
23	920420UME049	ROHIT VISHNU.K	5	5	4	4	2	20
24	920420UME050	AKILAN KARUPPAIAH.P	5	5	4	4	2	20
25	920420UME008	DHANUSH KUMAR.M	5	5	4	4	2	20
26	920420UME015	ANANTHA KANNAN.K	4	4	4	3	2	17
Faculty Signature			1-slow	2-medium	3- Good	4- fast	5-Excellent	

28-8-22

**CENTRE OF EXCELLENCE IN MANUFACTURING**  
**NATIONAL INSTITUTE OF TECHNOLOGY TIRUCHIRAPPALLI**  
 Internship for Kamaraj college of Engineering and Technology  
 23<sup>rd</sup> August – 28<sup>th</sup> August 2022  
 Assessment Batch 1

Sl.No	Reg No.	Student Name	Sketching	Modelling	Assembly	Drafting	Completion	Overall
1	920420UME001	SAKTHIVEL.K	5	5	4	3	3	20
2	920420UME002	RAHUL.K	5	5	4	4	2	20
3	920420UME003	LOGESH.A	5	5	5	5	2	22
4	920420UME004	RAJA SRINIVAS.M	5	5	3	3	2	18
5	920420UME005	SANTHOSH.V	5	5	5	3	2	20
6	920420UME007	HARISH.S	5	5	5	3	3	21
7	920420UME008	DHANUSH KUMAR.M	a	a	a	a	a	a
8	920420UME009	ALPHONSE SAM ANTO.G	5	5	5	5	1	21
9	920420UME010	SHANMUGASUNDARAM.M	a	a	a	a	a	a
10	920420UME011	VIGNESH.L	5	5	4	2	1	17
11	920420UME012	MAÑOJ KUMAR.M	4	4	4	4	3	19
12	920420UME013	ARULMURUGAN.K	4	4	4	4	3	19
13	920420UME014	NAVANEETHA KRISHNAN.P	4	4	3	3	3	17
14	920420UME015	ANANTHA KANNAN.K	a	a	a	a	a	a
15	920420UME016	JAIDEEP KUMAR.K	5	5	5	5	3	23
16	920420UME017	SHYAM.M.DA	5	5	5	5	5	25
17	920420UME019	JEEVA.K	5	5	5	5	2	22
18	920420UME020	BALAMANIKANDAN.V	5	5	4	4	2	20
19	920420UME021	BHARATH.M	5	5	4	4	2	20
20	920420UME022	SAIKISHORE.K	a	a	a	a	a	a
21	920420UME023	SIVAGURU.U	5	5	3	3	3	19
22	920420UME025	SHYAM GANESH.V	5	5	3	3	3	19
23	920420UME026	SHANMUGAPRIYAN.A.G	5	5	3	3	2	18
24	920420UME038	NAGENDRAN.J	5	3	3	3	2	16
Faculty Signature			1-slow	2-medium	3-Good	4-fast	5-Excellent	

Rg.  
46



**Department of Mechanical Engineering**

Title of the Program : Value Added Course on “NX-CAD”

Date: 23.08.2022 to 28.08.2022

Participants : III year

Software used : NX - CAD

Conducted by : COE in Manufacturing, NIT – Trichy

Venue : NIT - CAMPUS

**Grade for Batch I**

S.No	Batch	Full Name	Register NO	Total Marks (Out of 25)	Total Marks (Out of 100)
1	I	SAKTHIVEL.K	920420UME001	20	80
2	I	RAHUL.K	920420UME002	20	80
3	I	LOGESH.A	920420UME003	22	88
4	I	RAJA SRINIVAS.M	920420UME004	18	72
5	I	SANTHOSH.V	920420UME005	20	80
6	I	HARISH.S	920420UME007	21	84
7	I	ALPHONSE SAM ANTO.G	920420UME009	21	84
8	I	SHANMUGASUNDARAM.M	920420UME010	Absent	Absent
9	I	VIGNESH.L	920420UME011	17	68
10	I	MANOJ KUMAR.M	920420UME012	19	76
11	I	ARULMURUGAN.K	920420UME013	19	76
12	I	NAVANEETHA KRISHNAN.P	920420UME014	17	68
13	I	JAIDEEP KUMAR.K	920420UME016	23	92
14	I	SHYAM.M.DA	920420UME017	25	100
15	I	JEEVA.K	920420UME019	22	88
16	I	BALAMANIKANDAN.V	920420UME020	20	80
17	I	BHARATH.M	920420UME021	20	80
18	I	SAIKISHORE.K	920420UME022	Absent	Absent
19	I	SIVAGURU.U	920420UME023	19	76
20	I	SHYAM GANESH.V	920420UME025	19	76
21	I	SHANMUGAPRIYAN.A.G	920420UME026	18	72
22	I	NAGENDRAN.J	920420UME038	16	64

## Department of Mechanical Engineering

Title of the Program : Value Added Course on "NX-CAD"

Date: 23.08.2022 to 28.08.2022

Participants : III year

Software used : NX - CAD

Conducted by : COE in Manufacturing, NIT - Trichy

Venue : NIT - CAMPUS

Grade - Batch II

S.No	Batch	Full Name	Register NO	Total Marks (Out of 25)	Total Marks (Out of 100)
1	II	VIJAY.D	920420UME006	22	88
2	II	MAREESWARAN.R	920420UME018	21	84
3	II	SIVARAJ.K	920420UME024	20	80
4	II	KALAI SELVAN.R	920420UME027	20	80
5	II	HARIHARAN.N	920420UME028	19	76
6	II	THANGARAJ.T	920420UME029	21	84
7	II	HARISURIYA.M	920420UME030	22	88
8	II	PREM KUMAR.V.V	920420UME031	20	80
9	II	PRAVEEN.C	920420UME032	20	80
10	II	SILAMPARASAN.P	920420UME033	21	84
11	II	SATHISHKUMAR.D	920420UME034	24	96
12	II	KARTHIGAI SELVAN.R	920420UME036	21	84
13	II	THIRUMALAI RAJ.K	920420UME037	21	84
14	II	GOKULAKRISHNAN.E	920420UME039	24	96
15	II	SREE PRABHU.A	920420UME040	21	84
16	II	SARAVANA KUMAR.C	920420UME041	19	76
17	II	SABARIS.H.G	920420UME043	23	92
18	II	KESAVAN.J	920420UME044	23	92
19	II	RAJAGURU.C	920420UME045	22	88
20	II	CHANDRA KUMAR.G	920420UME046	20	80
21	II	AKASH.A	920420UME047	20	80
22	II	SUBRAMANIAN.P	920420UME048	19	76
23	II	ROHIT VISHNU.K	920420UME049	20	80
24	II	AKILAN KARUPPAIAH.P	920420UME050	20	80
25	II	DHANUSH KUMAR.M	920420UME008	20	80
26	II	ANANTHA KANNAN.K	920420UME015	17	68

Coordinators

HoD/MECH

Dean (Academic Courses)

Principal

# Feedback Form | III Year | Value Added Course

**Title of the Program** : Value added course for "NX-CAD"

**Participants** : III-year students

**Date** : 23.08.2022 to 28.08.2022

**Conducted by** : COE in Manufacturing, NIT – Trichy

**Software used** : NX-CAD

**Mode** : OFF Line

**Coordinators:**

Mr. Madhan N R, AP/Mech,

Mr. Sakthivel Murgan R, AP/Mech,

Department of Mechanical Engineering,

**Instructions:** Please indicate your level of agreement the statements listed below

4 Star - Strong Agree

3 Star - Agree

2 Star - Neutral

1 Star - Dis-Agree

\* Required

\* This form will record your name, please fill your name.

1. The objectives of the training were clearly defined by the Co-ordinator \*



2. Participation and interaction were encouraged.

\*



3. The topics covered were relevant to me.

\*



4. The content was organized and easy to follow.

\*



5. This training experience will be useful me. \*



6. The trainer was knowledgeable about the training topics.

\*



7. The trainer was well prepared.

\*



8. The trainer was well prepared.

\*



9. The training objectives were met.

\*



10. The training objectives were met.

\*



11. The time allotted for the training was sufficient

\*



12. The CAD Lab and CNC Machine were adequate and comfortable. \*



## Your view about this programme

13. What did you like most about this training?

\*

14. What aspects of the training could be improved?

\*

15. How do you hope to change your practice as a result of this training?

\*

16. Please share over all comments about this programme.

\*

17. Do you suggest this programme to your juniors \*

No

Yes

## Certificate Details

18. Kindly upload your certificate here.  
(Please share as a PDF within 5MB) \*

 Upload file

File number limit: 1 Single file size limit: 10MB Allowed file types: Word, Excel, PPT, PDF, Image, Video, Audio

This content is neither created nor endorsed by Microsoft. The data you submit will be sent to the form owner.

 Microsoft Forms

# Feedback Form |III Year | Value Added Course

46 Responses	09:25 Average time to complete	Active Status
-----------------	-----------------------------------	------------------

1. The objectives of the training were clearly defined by the Co-ordinator (0 point)



2. Participation and interaction were encouraged. (0 point)



3. The topics covered were relevant to me. (0 point)





4. The content was organized and easy to follow. (0 point)

46  
Responses

★★★★  
3.50 Average Rating

---

5. This training experience will be useful me. (0 point)

46  
Responses

★★★★  
3.57 Average Rating

---

6. The trainer was knowledgeable about the training topics. (0 point)

46  
Responses

★★★★  
3.52 Average Rating

---

7. The trainer was well prepared. (0 point)

46  
Responses

★★★★  
3.50 Average Rating

---

8. The trainer was well prepared. (0 point)

46  
Responses

★★★★  
3.50 Average Rating

---

9. The training objectives were met. (0 point)

46  
Responses

★★★★  
3.48 Average Rating

---

10. The training objectives were met. (0 point)

46  
Responses

★★★★  
3.37 Average Rating

---

11. The time allotted for the training was sufficient (0 point)

46  
Responses

★★★★  
3.35 Average Rating

---

12. The CAD Lab and Demo Session were adequate and comfortable. (0 point)

46  
Responses

★★★★  
3.50 Average Rating

---

13. What did you like most about this training? (0 point)

46  
Responses

Latest Responses

- "cnc machine"
- "Good"
- "Yes "

9 respondents (20%) answered **Cnc** for this question.



14. What aspects of the training could be improved? (0 point)

46  
Responses

Latest Responses

- "Nothing"
- "Skills development"
- "Nothing "

6 respondents (13%) answered **good** for this question.



15. How do you hope to change your practice as a result of this training? (0 point)

46  
Responses

Latest Responses

- "Nothing"
- "Good"
- "Nothing "

8 respondents (17%) answered **good** for this question.



16. Please share over all comments about this programme. (0 point)

46  
Responses

Latest Responses

- "Nice"
- "Nil"
- "Nice"

12 respondents (26%) answered **Good** for this question.



17. Do you suggest this programme to your juniors (0 point)

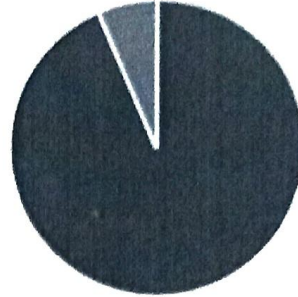

- Yes 43
- No 3



18. Kindly upload your certificate here. (0 point)  
(Please share as a PDF within 5MB)

46  
Responses

Latest Responses

-  navaneetha krishnan\_NAVANEETHAKRISHNAN.P.pdf
-  New doc Feb 26, 2022 3.44 PM\_SAIKISHORE.K(ME).pdf
-  cipet\_SIVAGURU.U(ME).pdf

*Handwritten signature*  
R. durg

*overall comments are good*  
*S.S. Sundhara*

## Department of Mechanical Engineering

**Title of the Program :** Value Added Course on "NX-CAD"

**Date:** 23.08.2022 to 28.08.2022

**Participants :** IIII year

**Software used :** NX - CAD

**Conducted by :** COE in Manufacturing, NIT – Trichy

**Venue :** NIT - CAMPUS

### Summary report

On 23.08.2022, the programme was started by 9.00 AM to Batch I students. Basics of Sketching mode in NX-CAD was taught by the trainer Dr. Anandha Krishnan, Associate Professor cum Centre Incharge, NIT – Trichy. During the afternoon, students was practicing the same.

On 24.08.2022, 3D Modelling mode was taught by the trainer in NX-CAD. During the afternoon, 3D Assembly in NX-CAD was taught and simultaneously they were practicing the module.

On 25.08.2022, Students were practicing the assembly model which was given by the trainer, doubt from the students were clarified by them. During the afternoon, Assessment was given to the students and output was evaluated by the trainer.

Similar to the Batch I programme schedule; Batch II was conducted as it is.

#### Batch Details:

Batch Details	Batch Size	Duration
1	20	23.08.2022 to 25.08.2022
2	28	26.08.2022 to 28.08.2022

#### Sample Photo Proof:

**Practical Demo**

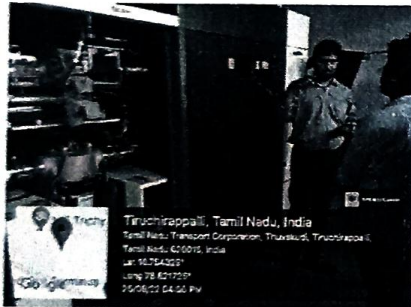

**Doubt Clearing Session**

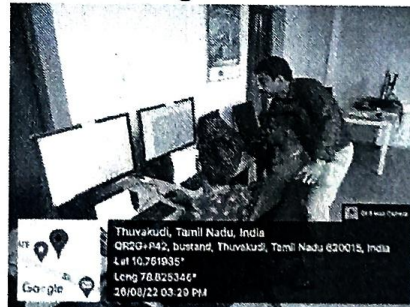

**Assessment**

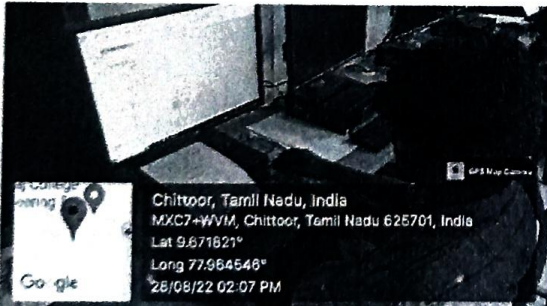

**Valedictory Ceremony**



*N. R. Raju*  
**Coordinators**

*[Signature]*  
**HoD/Mech**